

100G QSFP28 Active optical cable

Features

- Support 100GBASE-SR4/EDR application
- Compliant to QSFP28 Electrical MSASFF-8636
- Multi rate of up to 25.78125 Gbps
- Transmission distance up to 100m
- +3.3V single power supply
- Low power consumption
- Operating temp
Commercial: 0°C to +70°C
- RoHS compliant
- UL certification cables (optional)

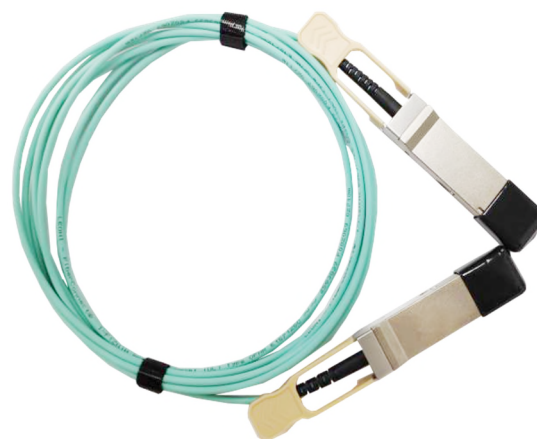

Applications

- 100GBASE-SR4 at 25.78125 Gbps per lane
- InfiniBand QDR, EDR
- Other optical links

Absolute Maximum Ratings

Table 1- Absolute Maximum Ratings

Parameter	Symbol	Min.	Typical	Max.	Unit	Notes
Supply Voltage	V _{CC3}	-0.5	-	+3.6	V	
Storage Temperature	T _s	-10	-	+70	°C	
Operating Humidity	RH	+5	-	+85	%	1

Note: 1 No condensation

Recommended Operating Conditions

Table 2- Recommended operating Conditions

Parameter	Symbol	Min.	Typical	Max.	Unit	Notes
Operating Case Temperature	T _c	0	-	+70	°C	
Power Supply Voltage	V _{CC}	3.14	3.3	3.47	V	
Power Dissipation	P _d	-	-	2.5	W	1
Bit Rate	BR	10.3125	25.78125	-	Gbps	

Note: 1 Per terminal

Electrical Characteristics

Table 3- Electrical Characteristics

Parameter	Symbol	Min.	Typ.	Max.	Units	Notes
ModSelL	Module Select	V_{OL}	0	-	0.8	V
	Module Unselect	V_{OH}	2.5	-	V_{CC}	V
LPMode	Low Power Mode	V_{IL}	0	-	0.8	V
	Normal Operation	V_{IH}	2.5	-	$V_{CC}+0.3$	V
ResetL	Reset	V_{IL}	0	-	0.8	V
	Normal Operation	V_{IH}	2.5	-	$V_{CC}+0.3$	V
ModPrsL	Normal Operation	V_{OL}	0	-	0.4	V
IntL	Interrupt	V_{OL}	0	-	0.4	V
	Normal Operation	V_{OH}	2.4	-	V_{CC}	V
Electrical transmitter Characteristics						
Differential Data Input Swing	$V_{in, p-p}$	200	-	1600	mV	
Output Differential Impedance	Z_{in}	90	100	110	Ω	
Electrical Receiver Characteristics						
Differential Data Output Swing	V_{out}	200	-	800	mV	
Bit Error Rate	BER	-	-	E-12	-	1
Input Differential Impedance	Z_D	90	100	110	Ω	

Note:1 PRBS2^31-1@25.78125Gbps

Recommended Interface Circuit

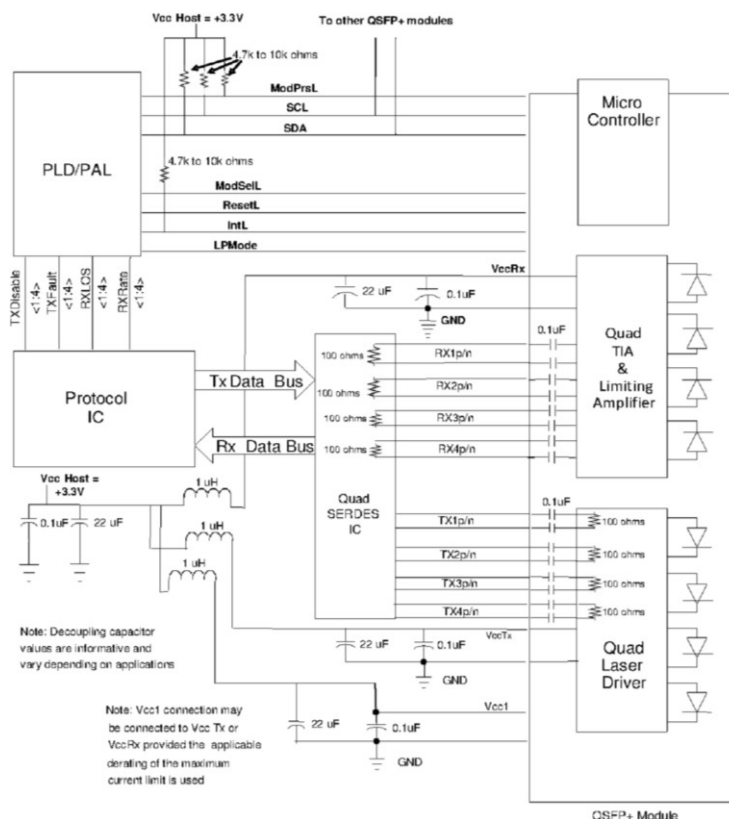

Figure 1, Recommended Interface Circuit

REV:A0

Pin arrangement

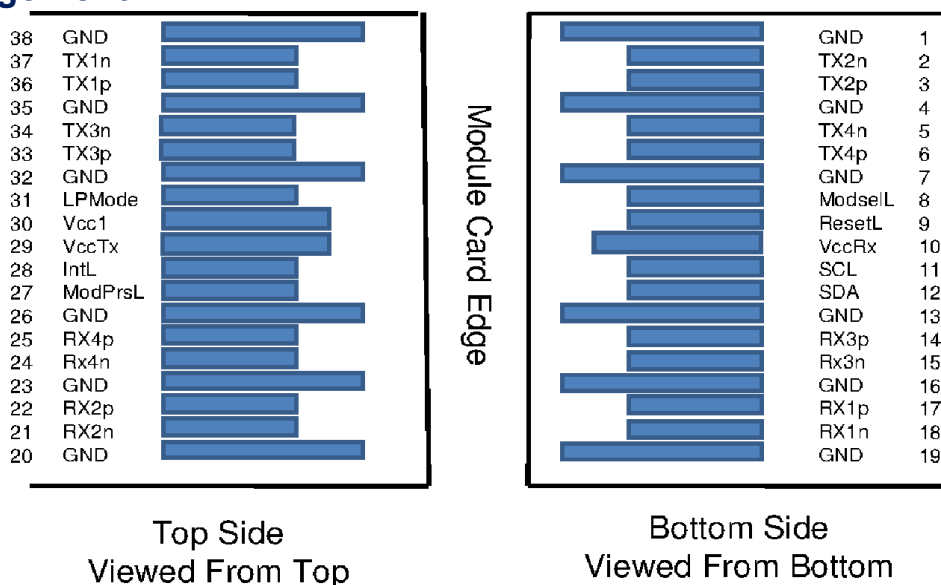

Figure 2, Pin View

Table 4-Pin Function Definitions

Pin	Symbol	Name/Description	Notes
1	GND	Ground	1
2	Tx2n	Transmitter Inverted Data Input	
3	Tx2p	Transmitter Non-Inverted Data Input	
4	GND	Ground	1
5	Tx4n	Transmitter Inverted Data Input	
6	Tx4p	Transmitter Non-Inverted Data Input	
7	GND	Ground	1
8	ModSelL	Module Select	
9	ResetL	Module Reset	
10	Vcc Rx	+3.3V Power Supply Receiver	
11	SCL	2-wire serial interface clock	
12	SDA	2-wire serial interface data	
13	GND	Ground	1
14	Rx3p	Receiver Non-Inverted Data Output	
15	Rx3n	Receiver Inverted Data Output	
16	GND	Ground	1
17	Rx1p	Receiver Non-Inverted Data Output	
18	Rx1n	Receiver Inverted Data Output	
19	GND	Ground	1
20	GND	Ground	1
21	Rx2n	Receiver Inverted Data Output	
22	Rx2p	Receiver Non-Inverted Data Output	
23	GND	Ground	1
24	Rx4n	Receiver Inverted Data Output	

Pin	Symbol	Name/Description	Notes
25	Rx4p	Receiver Non-Inverted Data Output	
26	GND	Ground	1
27	ModPrsL	Module Present	
28	IntL	Interrupt	
29	Vcc Tx	+3.3V Power supply transmitter	
30	Vcc1	+3.3V Power supply	
31	LPMoDe	Low Power Mode	
32	GND	Ground	1
33	Tx3p	Transmitter Non-Inverted Data Input	
34	Tx3n	Transmitter Inverted Data Input	
35	GND	Ground	1
36	Tx1p	Transmitter Non-Inverted Data Input	
37	Tx1n	Transmitter Inverted Data Input	
38	GND	Ground	1

Note: 1. Circuit ground is internally isolated from chassis ground.

Monitoring Specification

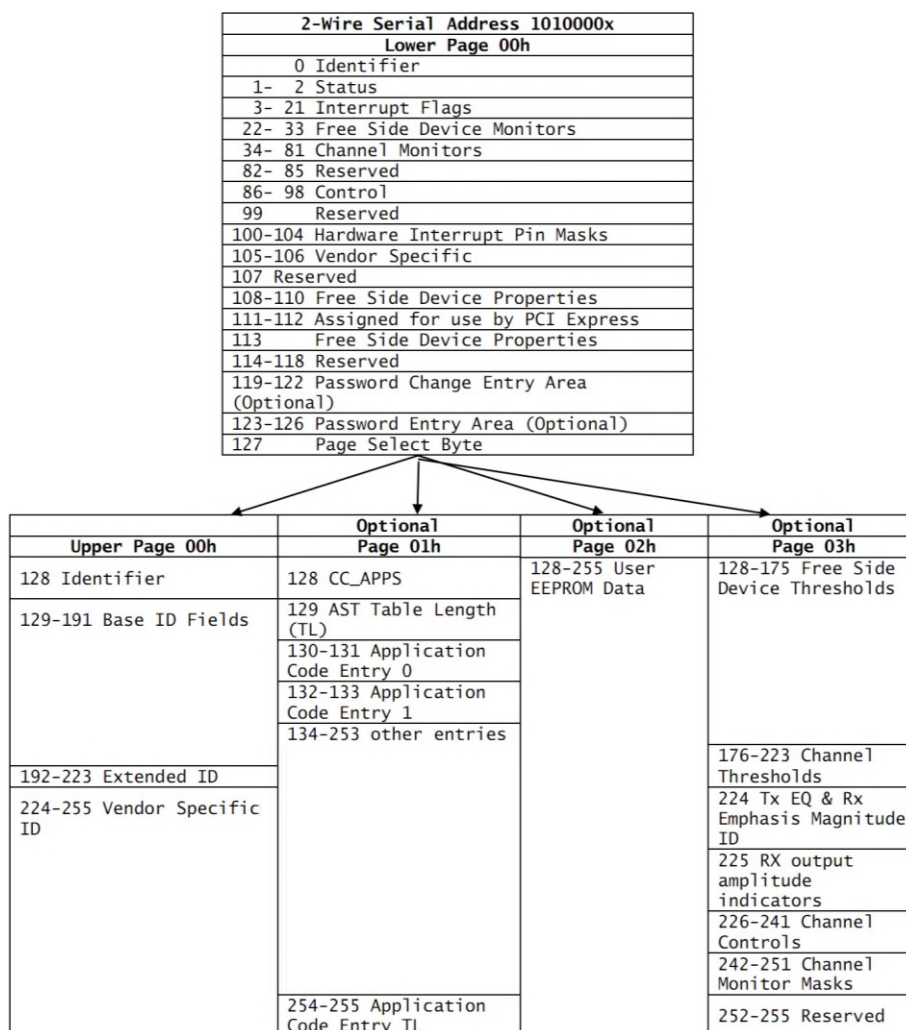

Figure 3, Memory Map

Mechanical Design Diagram

Unit mm

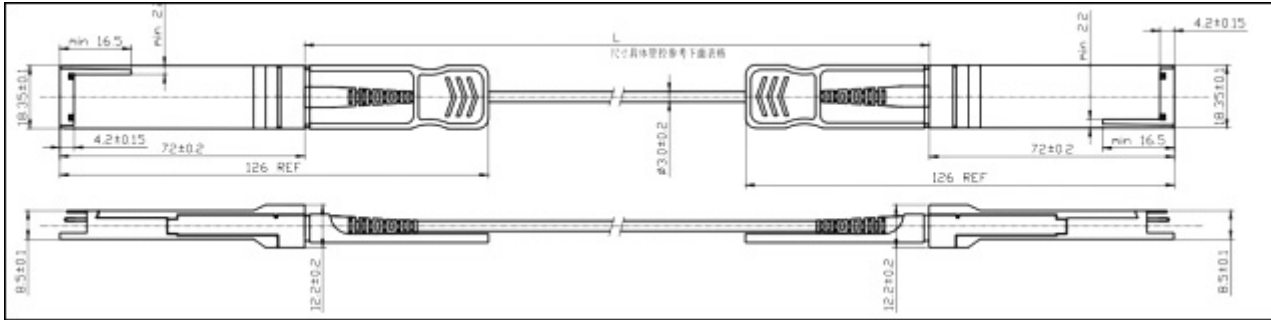

Table 5- Cable Length

Cable Length L (Unit: m)	Tolerant (Unit: cm)
≤ 1.0	+5/-0
$1.0 < L \leq 4.5$	+15/-0
$4.5 < L \leq 14.5$	+30/-0
> 14.5	+2%/-0

Warnings

Handling Precautions: This device is susceptible to damage as a result of electrostatic discharge (ESD).

A static free environment is highly recommended. Follow guidelines according to proper ESD procedures.

Laser Safety: Radiation emitted by laser devices can be dangerous to human eyes. Avoid eye exposure to direct or indirect radiation.