

## FTTH Termination Box

STB-24C

### Description

The equipment is used as a termination point for the feeder cable to connect with drop cable in FTTx communication network system. The fiber splicing, splitting, and distribution can be done in this box, and meanwhile it provides solid protection and management for the FTTx network building.

### Features

- Advanced structure design, easy operation and reasonable routing.
- Material: PP or PC+ABS.
- Moisture proof, waterproof, dust-proof, anti-aging.
- Protection level up to IP68.
- 1 oval optical cable entry, 2 branch optical cable entries and 24 pcs of household.
- Installation method: pole-mounted, aerial-mounted, wall-mounted.
- complies with the RoHS environmental protection directive.

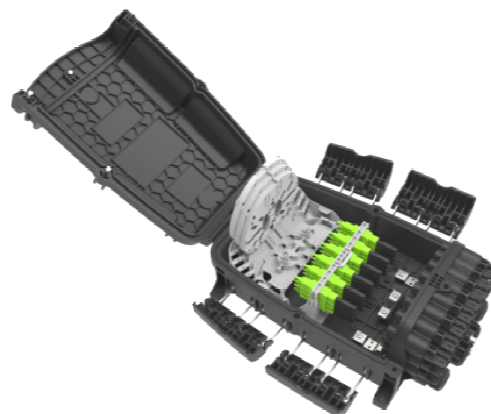
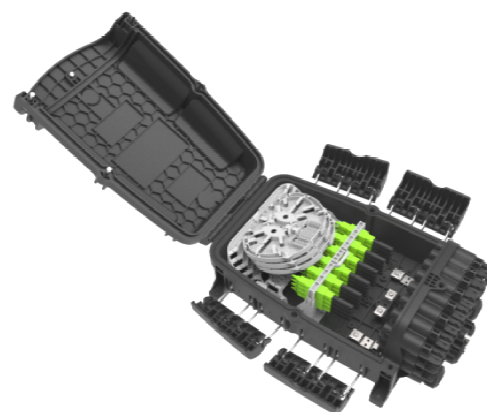

### Specification

Item	Specifications	Remark
External dimension	378 mm *255 mm *136 mm (A*B*C)	
Installation hole position	215 mm *266 mm *239 mm (D*E*F)	
Color	Black	Customizable
Operation temperature	-40 °C~+65 °C	
Atmospheric pressure	70~106Kpa	
Size and quantity of optical cable hole	1 oval optical cable entry, 2 branch optical cable entries and 24pcs of household	

Fusion capacity(Max)	48	Tray A ,12x4=48, 2 layers of heat-shrinkable splice protection sleeve.
	64	Tray B, 8x8=64, 1 layer of heat-shrinkable splice protection sleeve.
	96	Tray C, 8x12=96, 1 layer of heat-shrinkable splice protection sleeve.
	96	Tray D, Tray E, 24x4=96, 2 layers of heat-shrinkable splice protection sleeve.
	108	Max:4E+C=24*4+12=108
Micro PLC Splitter	1x2	Splitter size: 60x7x4mm. Can be installed in type A, type C and type E splicing tray, 1 PC per splicing tray.
	1x4	
	1x8	
	1*16	Splitter size: 60x12x4mm. Can be installed in type A-1, and type E-1 splicing tray, 1 PC per splicing tray.
Into the largest cable diameter	≤15mm	*Note: Provide the type and diameter of the optical cable when purchasing, to matching the appropriate sealing plug to ensure the sealing performance.
Maximum size of bifurcation hole	≤ 12mm	
Cable outlet size(mm)	2*3 ~ ∅7	
IP protection level	IP68	
Flammability	HB(Conventional)	can be customized according to requirements
Neutral salt spray test (NSS)	48 h	

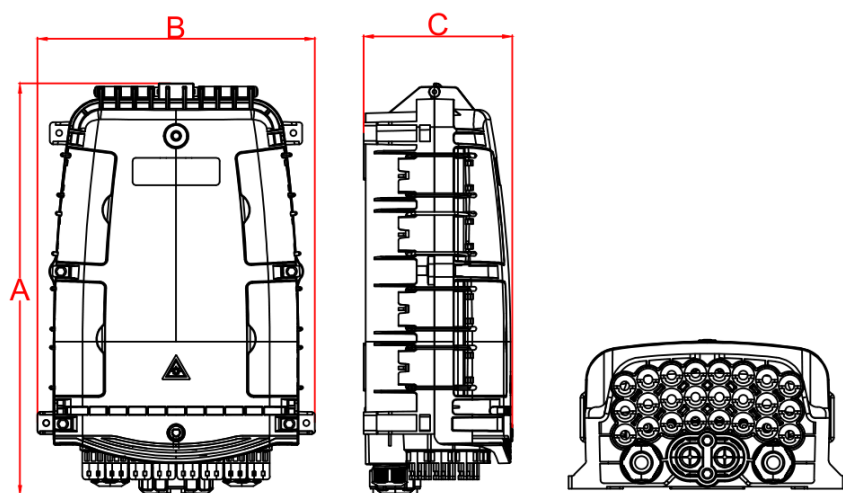

Pic 1 Box Size

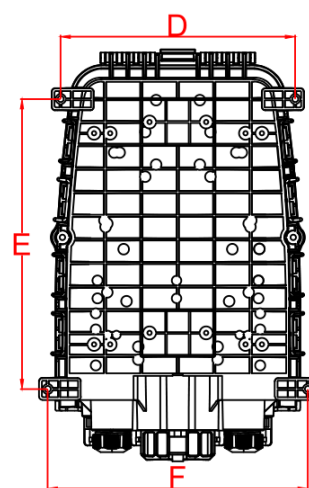

Pic 2 Installation Size

## Configuration

- Main optical parameters

Splitter or pigtail	IL(dB)	RL(dB)	IL(dB)	Test method
	Pigtail/Splitter		Distribution box	
Pigtail-SC/APC-00-SM-SX(1C1F)-OD0.9MM-PVC-G657A2-Cable Color(Default)-Indoor-RoHS-1.5m	≤0.3	≥55dB	≤0.5	IL: IEC61300-3-4 Method B RL: IEC61300-3-6 Method 1
1x2 PLC Splitter, with SC/APC connector	≤4.0	≥55dB	≤4.2	
1x4 PLC Splitter, with SC/APC connector	≤7.4	≥55dB	≤7.6	
1x 8 PLC Splitter, with SC/APC connector	≤10.5	≥55dB	≤10.7	
1x 16 PLC Splitter, with SC/APC connector	≤13.5	≥55dB	≤13.7	

The optical parameters shown in the table above are default values, and can be customized according to requirements.

## Product cable ways

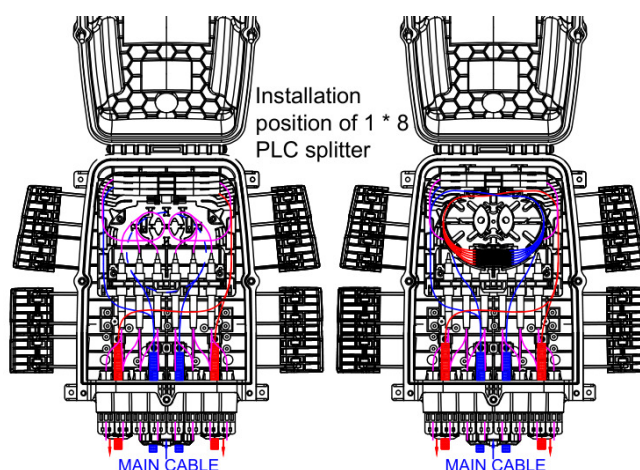



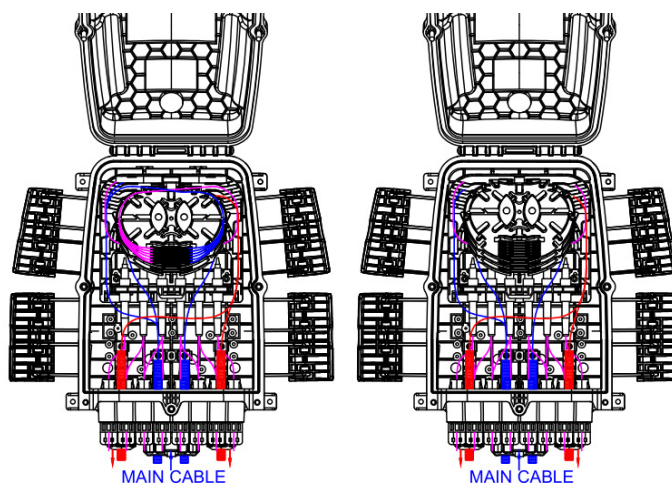



Pic 3 Cable ways



Pic 4 Cable ways

## Splicing tray

Item	Splicing tray A	Splicing tray B	Splitter tray A-1
Dimensions (H*W*D, mm)	134*104*8	134*104*4	134*104*8
Net weight (kg)	0.021	0.015	0.021
Picture			
Color	RAL7035	RAL7035	RAL7035
Material	PC+ABS	PC+ABS	PC+ABS
Splicing capacity of a tray(cores)	12 (2 layers of heat shrinkable protective sleeve)	8 (1 layer of heat shrinkable protective sleeve)	6 (2 layers of heat shrinkable protective sleeve)
Splitter capacity of a tray(PCS)	1 (PLC 1X2, 1X4, 1X8, 0.9mm fiber,60x7x4mm)	/	1 (PLC 1X16, 0.9mm fiber,60x12x4mm)
Maximum(PCS)	4	8	4
Default(PCS)	3	/	/
Note: 1.The above trays can be mixed according to requirements. 2.Configuration rules: 1A=2B=2C=1D=1E. 3.The types of fiber discs are increasing continuously.			

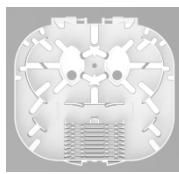
Item	Splicing tray C	Splicing tray D	Splicing tray E	Splicing tray E-1
Dimensions (H*W*D, mm)	136 * 104 * 4	136 * 104 * 8	135 *125*8	135 *125*8
Net weight (kg)	0.018	0.024	0.033	0.033
Picture				
Color	RAL7035	RAL7035	RAL7035	RAL7035
Material	PC+ABS	PC+ABS	PC+ABS	PC+ABS
Splicing capacity of a tray(cores)	12 (1 layer of heat shrinkable protective sleeve)	24 (2 layers of heat shrinkable protection sleeve)	24 (2 layers of heat shrinkable protection sleeve)	18 (2 layers of heat shrinkable protection sleeve)
Splitter capacity of a tray(PCS)	/	/	1 (PLC 1X2, 1X4, 1X8, 0.9mm fiber,60x7x4mm)	1 (PLC 1X16, 0.9mm fiber,60x12x4mm)
Maximum(PCS)	8	4	4	4

Default(PCS)	/	/	/	/
Note: 1.The above trays can be mixed according to requirements. 2.Configuration rules: 1A=2B=2C=1D=1E. 3.The types of fiber discs are increasing continuously.				

## Installation

- Wall-mounted installation

Drill 4 holes in the wall according to the dimension, place the expansion plug  $\Phi 7.5 \times 40$ , place the box to match up the holes and use screws to fasten. (Pic 5)



Pic 5 Wall mounted installation

- Pole-mounted installation

Pass the hoop ring through the slot of the back plate and fix it on the telecommunication pole. (Pic 6)



Pic 6 Pole mounted installation

- The overhead structure

Tie the two installed on the chassis of the overhead hung on the wire, and then bolted, prevent the case fall off. (Pic 7)

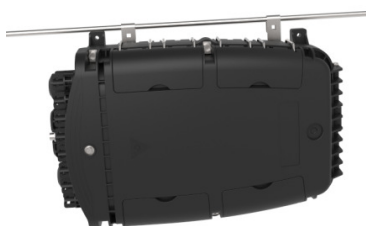

Pic 7 The overhead structure